



# Preliminary

... a link to the future



## Product Information

VX 26H / VX 26L Distribution amplifier local powered  
VX 29H / VX 29L Distribution amplifier remote powered



### **WISI VALUE LINE**

- ⦿ Die cast housing
- ⦿ Return amplifier and diplex filter on board
- ⦿ Passive return path can be enabled by jumpers
- ⦿ All adjustments by Rotary Switches or jumpers
- ⦿ Plug-in output splitter

# VX 26x, VX 29x **WISI VALUE LINE** - Distribution amplifiers



WISI Q-step is unique feature of WISI CATV amplifiers. High precision electronic attenuators are controlled by means of reliable digital code switches to ensure a stable and visible alignment without the need of accessories like pads and equalizers. At the same time this feature ensures a continuous up- and downstream RF service to the connected subscribers.

## Specifications



### Downstream

Frequency range		85-1002 MHz
Gain	H version	41 dB
	L version	32 dB
Output level CENELEC 42ch, flat		111 dB $\mu$ V
	- 6 dB slope	114 dB $\mu$ V
	- CSO	$\geq$ 60 dB
	- CTB	$\geq$ 60 dB
Noise figure		$\leq$ 6 dB up to 600 MHz
		$\leq$ 8 dB up to 862 MHz



Attenuator	1-dB-steps	0-15 dB
Equalizer	1.5-dB-steps	0-22.5 dB
Interstage equalizer (Jumper)		0 / 6 / 12 dB
Interstage attenuator (Jumper)		0 / 5 dB
HF output test socket		-20 dB (directional coupler)
Input test point		-20 dB (resistive test point)

### Return path

Frequency range		5-65 MHz
Gain active // passive		24 dB / $\pm$ 0.5 dB // -4 dB
Noise figure		$\leq$ 6 dB
Output level 2nd, 3rd order		typ. 112 dB $\mu$ V
Input attenuator	1-dB-steps	0-15 dB
Output attenuator		0-15 dB
Interstage attenuator (Jumper)		0 / 5 dB
Interstage equalizer (Jumper)		0 / 3 / 6 / 9 dB

## General

Operating voltage	VX 26x: 180-265 VAC / VX 29x: 27-65 VAC / 50/60 Hz
Power consumption	typ. 18 W
HF connectors	VX 29x - PG 11 / VX 26x - F
Power passing	VX 29x (per port) < 7A
Environmental protection	IP 66
EMC	EN 50083-2
Operating temperature	-20 °C...+55 °C
Dimensions	236x145x90 mm

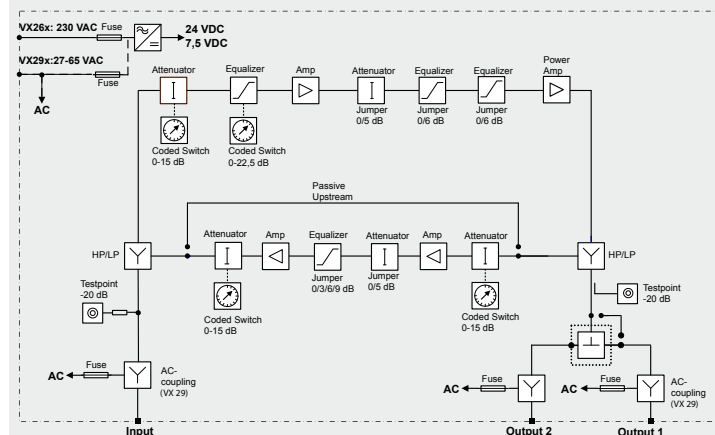

**WISI Communications GmbH & Co. KG**  
Empfangs- und Verteiltechnik  
P.O. BOX 1220  
75219 Niefern-Oeschelbronn, GERMANY  
Phone +49(0)7233/66-280  
Fax +49(0)7233/66-350  
www.wisi.de  
export@wisi.de

Technical Modifications reserved. WISI cannot be held liable for any printing error.  
084 014 / 01.08

... a link to the future